

HI-PERFORMANCE MALFUNCTION DETECTOR

SAFETY DEVICE PS-661

INSTRUCTION MANUAL

Program version 1.0x

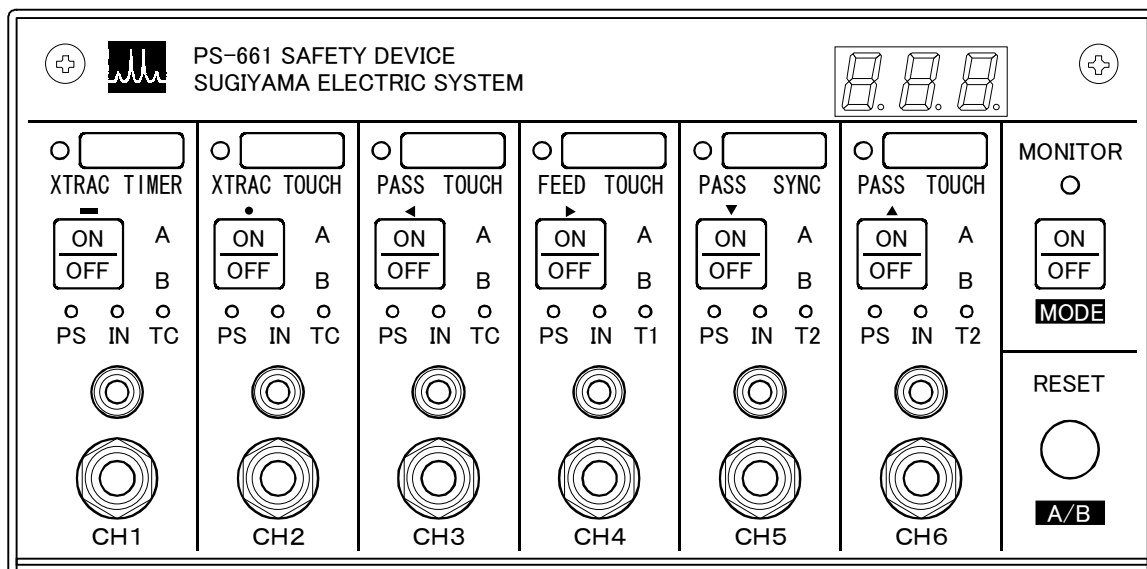

Thank you very much because PS-661 is had to be purchased this time indeed.

PS-661 is a malfunction detector, which was designed by making good use of know how and the computer technology, which accumulated for many years.

Please read well this instruction manual in before use to understanding the performance of this detector's useful function.

SUGIYAMA ELECTRIC SYSTEM INC.



Warning

This device is used to decrease the damage of the die and to decrease generation of the defective products.

It is not guaranteed that the die does not break and defective products are not generated.

Use the voltage of the power source with AC100-240V.

When the power which exceeds specification voltage is applied, PS-662 cause a fire.

Do not touch the terminal block.

Touching the metal part of the terminal block causes the electric shock.

Do not decompose, repair nor remodel the device by the customer because of danger.

When break down, remove the power source immediately and do not use.

IF there are smoke, heat and smells strange, remove the power source immediately and discontinue using under the abnormal situation.



Attention

Fix this device surely.

Do not use the detector under the splash water and other liquids to causes the breakdown, a fire, and the electric shock.

Check before use.

After power ON, confirm each function operates normally.

Contents

1. Description	1
1-1. Features	1
2. Each part explanation	2
2-1. Panels	2
2-1-1. Detection channel	3
2-1-2. Monitor ON/OFF button, lamp	4
2-1-3. Reset button	4
2-1-4. Digital display	4
2-1-5. Terminal block	4
2-1-6. Output connector	5
2-1-7. Power switch	6
2-2. Power cable	6
2-3. SPRING sensor	6
3. Functions	7
3-1. Malfunction detector	7
3-2. Detection channel	8
3-3. Sensor input	9
3-4. Detection timing input	9
3-5. Function setting	10
3-6. Detection mode	10
3-6-1. Touch detection	10
3-6-2. Synchronization detection	10
3-6-3. Passage detection	11
3-6-4. Miss-feed detection	12
3-6-5. Extraction detection	13
3-6-6. Timer detection	13
3-7. Automatic monitor ON	14
3-8. Panel setting memory	14
3-9. Device setting	14
4. Operation	15
4-1. Monitor ON/OFF	15
4-2. Release of stop output	15
4-3. Detection ON/OFF of channel	16
4-4. Change of input polarity	16
4-5. Change of detection mode	16
4-6. Function setting	17
4-6-1. Touch and synchronization detection	17
4-6-2. Extraction detection	17
4-6-3. Timer detection	18
4-6-4. Miss-feed detection	18
4-6-5. Passage detection	18
4-7. Panel setting memory	18

5. Installation	19
5-1. Installation of safety device	19
5-2. Connection of power supply	20
5-3. Connection of stop output	20
5-4. Connection of continuous inhibition output	21
5-5. Connection of alarm output	21
5-6. Connection of external reset and monitor ON/OFF switches.	21
5-7. Connection of operation inhibition switch	22
5-8. Connection of detection timing inputs	22
5-9. Connection of sensors	22
6. Device setting	23
6-1. Switch to device set mode	23
6-2. Item number setting, display and change in set content	23
6-3. End of device set mode	23
6-4. Initialization of setting	23
6-5. Details of setting	24
6-5-1. Automatic returns count (item number 1)	24
6-5-2. Reset output time (item number 2)	24
6-5-3. Monitor ON/OFF output time (item number 3)	24
6-5-4. Output polarity 1 (item number 4)	24
6-5-5. Output polarity 2 (item number 5)	24
6-5-6. Input polarity 1 (item number 6)	25
6-5-7. Input polarity 2 (item number 7)	25
6-5-8. System setting (item number 8)	25
6-5-9. Reservation item (item number 9)	25
6-5-10. Option output (item number 10)	25
6-5-11. Operation inhibition setting 1 (item number 11)	25
6-5-12. Operation inhibition setting 2 (item number 12)	26
6-5-13. Input signal processing time (item number from 13 to 18)	26
6-6. Set item list (V1.0x)	26
7. Specification and performance	27
7-1. Detection	27
7-2. Input circuit	27
7-3. Output circuit	27
7-4. Power supply	27
7-5. Other specifications	27
8. Dimensions	28

1. Description

Safety device PS-661 is a malfunction-detecting device to monitor processing stamping, such as material end, miss-feeding and products miss-ejection in automatic press stamping.

PS-661 inspects the processing by the sensor input and the detection-timing signal, which synchronizes with press machine. When the malfunction is detected, the stop signal is output to the press machine.

1-1. Features

- The detection mode can be changed.
Two detection modes are built in each detection channel. The combination of the detection modes is different in each channel.
- The sensor input polarity of each channel can be switched.
- All detection channel has the pin jack and the three pole jack.
The contact type sensor is connected with pin jack. The sensor (photo sensor and proximity sensor, etc.) which needs the power supply is connected with three pole jack.
- The detection channel under use is displayed.
The detection lamp illuminates in green when the channel under use. When a malfunction is detected, the detection lamp blinks red.
- The operation stop of the safety device was made easy to confirm.
When the detection operation is stopped, some lamps are turned off.
- An unnecessary operation can be excluded.
When the operation inhibition input in the terminal block is turned on, buttons other than reset and monitor cannot be operated.

2. Each part explanation

2-1. Panels

In a front panel, there are six detection channels, reset button, monitor ON/OFF button, and digital display of three digits.

The back panel includes the output connector, the terminal block, and the power switch, etc.

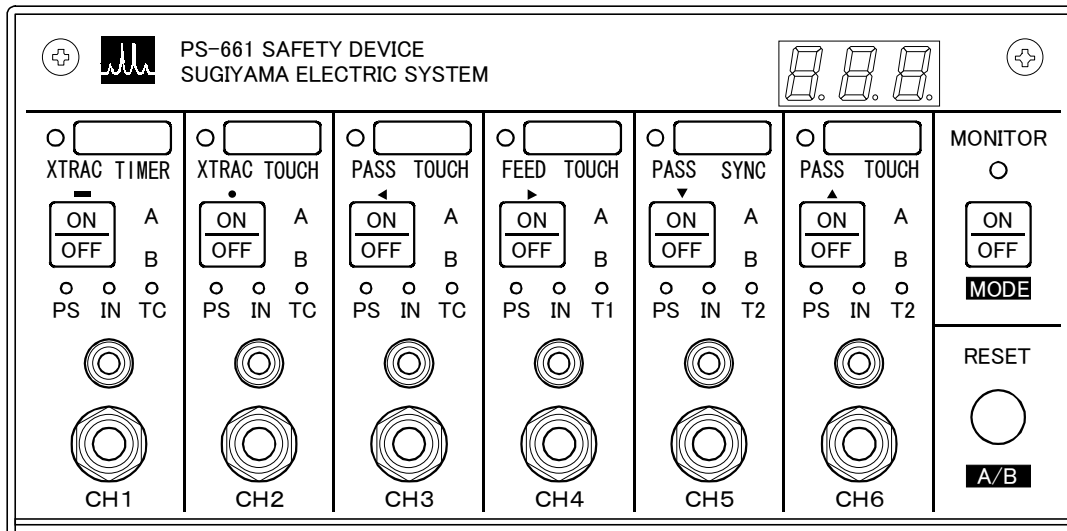

PS-661 front panel

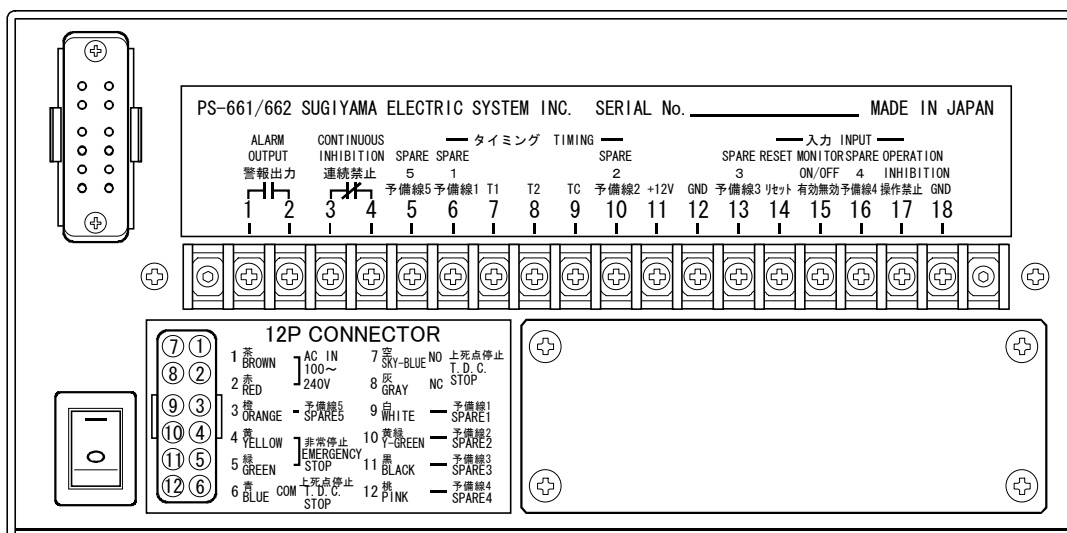

PS-661 back panel

2-1-1.Detection channel

The operation/detection lamp displays the state of the channel. When the detection of the channel is on, the lamp illuminates in green. The lamp is turned off when detection off. When the malfunction is detected, the lamp blinks red.

When the detection lamp blinks red, the stop signal is output. Push the reset button to release the stop signal.

Pushing detection ON/OFF button can change detection on/off.

The detection mode indicator displays the detection method. The combination of the detection methods is different in each channel.

Push detection ON/OFF button with the mode (monitor ON/OFF) button pushed to change the detection mode.

The sensor input polarity indicator displays A or B. The polarity indicator is turned off in detection off. Push detection ON/OFF button with the A/B (reset) button pushed to change the input polarity.

Detection ON/OFF button is used by detection ON/OFF change of the channel. Moreover, detection ON/OFF button is used to change in the sensor-input polarity and the detection mode, etc.

In the operation status lamp, there are PS, IN, and Tx.

The PS lamp displays the passage-signal memory. There is a detection mode to which the PS lamp does not illuminate.

The IN lamp displays the state of the sensor-input signal. The IN lamp illuminates when the input signal is effective.

The Tx lamp displays the detection-timing signal. The detection-timing signal input is in the terminal block. Tx is printed as T1, T2 or TC.

The sensor is connected with pin jack and three pole jack. The sensor that requires no power source such as the SPRING SENSOR and two wire type proximity switches is connected with pin jack.

The LIGHT SENSOR, the LOOP SENSOR, and three-wire type proximity switch are connected with three pole jack.

Two sensor signals in the detection channel are connected internally. Neither pin jack nor three pole jack must connect the sensor at the same time.

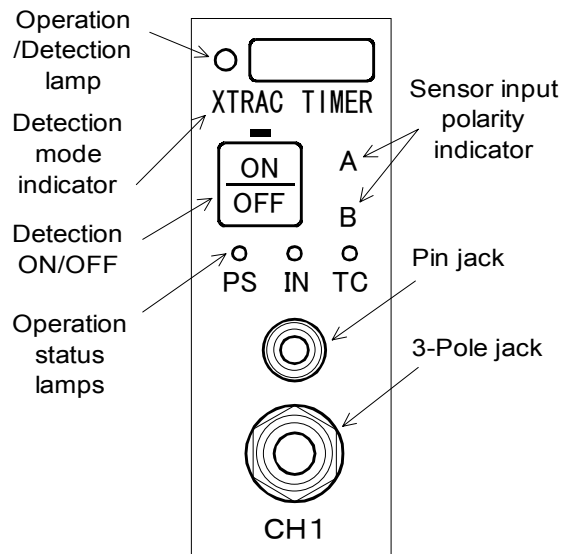

Detection channel

2-1-2. Monitor ON/OFF button, lamp

Monitor ON/OFF button changes detection function on/off of the safety device.

The monitor lamp illuminates in green by detection function ON of the safety device. Red blinks by detection function OFF.

In detection function ON, the continuous inhibition output relay is turned on.

Monitor ON/OFF button is used as a shift button of the detection mode change operation. Pushing detection ON/OFF button with the mode (Monitor ON/OFF) button pushed can change the detection mode.

MONITOR

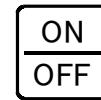

MODE

Monitor ON/OFF
Button, lamp

2-1-3. Reset button

The stop output and the error of the safety device are released with the reset button.

Reset button is used as a shift button of the sensor input polarity change operation. Pushing detection ON/OFF button with the A/B (reset) button pushed can change the sensor-input polarity.

RESET



A/B

Reset button

2-1-4. Digital display

The digital display is used by the display/the change in the content of the detection mode function setting.

Moreover, when the memory backup battery voltage decreases, the error (E-01) is displayed.

The content of the detection mode function setting includes setting at time in the timer detection and the number of setting by the extraction detection, etc. The content of the function setting is different according to the detection mode.

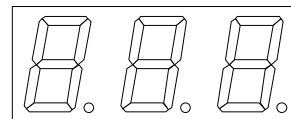

Digital display

2-1-5. Terminal block

The terminal block includes a relay output, a detection timing input, and a spare wire, etc.

The alarm output (1,2) is an output of the relay contact. The relay contact close by output ON. The alarm output is turned on at the same time as the emergency stop or T.D.C. stopping. The buzzer and warning light are connected with the alarm output usually.

The continuous inhibition (3,4) is an output of the relay contact. This relay contact output close while monitor ON. The continuous inhibition output is connected with the press control circuit so that the press machine may become shutdown when the safety device is monitor OFF.

T1 (7), T2 (8), TC (9) are detection timing inputs. Connect the rotary cam and the timing sensor etc. of the press device with the detection timing input.

+12V(11) is a power source for the timing sensor. Use current by 100mA or less.

The safety device does not work when short-circuited +12V terminal and other terminal. Be not short-circuited.

Spare wire (5,6,10,13,16) is connected with the output connector. Uses the spare wires when connect the signal of the terminal block through the power cable.

Reset input (14) is an input of the stop output release. When the stop output is released with the reset button in the panel, the input terminal temporarily becomes a reset output. The reset output is turned on at 0.2 seconds.

Monitor ON/OFF (15) input can turn the detection function of the safety device on and off.

Operation inhibition input (17) is an input to inhibit the panel operation. Connect the operation inhibition input with the GND of terminal block to inhibit the panel operation.

GND (12,18) is a common terminal of the terminal block input. GND is connected with the chassis internally.

Attention: Connect the contact or the contact-less signal of the no-voltage with the terminal block input. When the voltage is applied, an internal circuit might be destroyed.

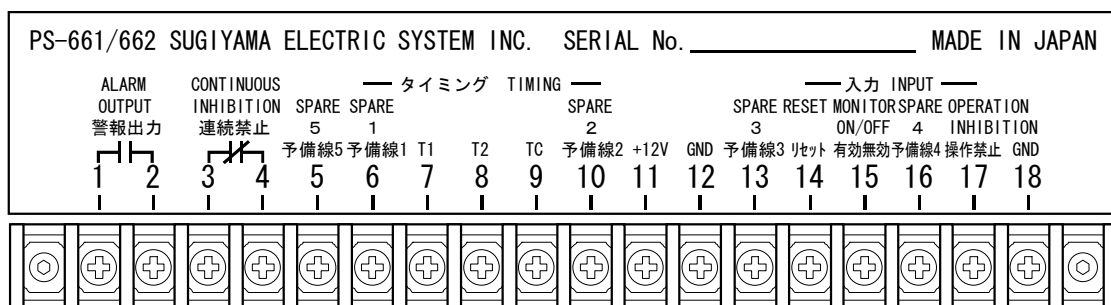

Terminal block

2-1-6. Output connector

In the output connector, there are a power wire of the safety device, a stop output, and a spare wire. Connect and use the cable with a special connector.

Supplies from AC100 to 200V, to the power input (1-Brown, 2-Red).

The emergency stop output (4-Yellow, 5-Green) is a relay contact output. Connect the output with the emergency stop circuit of the press machine.

The T.D.C. stop output (6-Blue, 7-Sky-blue, 8-Gray) is a relay contact output. Connect the output with the T.D.C. stop circuit of the press machine.

The spare wires (3-Orange, 9-White, 10-Yellow green, 11-Black, 12-Pink) is connected with the terminal block in the safety device.

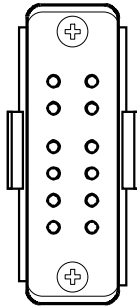

12P CONNECTOR				
⑦ ①	1 茶 BROWN	AC IN 100~240V	7 空 SKY-BLUE NO	上死点停止 T.D.C.
⑧ ②	2 赤 RED	予備線5 SPARE5	8 灰 GRAY	NC STOP
⑨ ③	3 橙 ORANGE		9 白 WHITE	予備線1 SPARE1
⑩ ④	4 黄 YELLOW	非常停止 EMERGENCY STOP	10 黄绿 Y-GREEN	予備線2 SPARE2
⑪ ⑤	5 绿 GREEN		11 黑 BLACK	予備線3 SPARE3
⑫ ⑥	6 青 BLUE	上死点停止 T.D.C. STOP	12 桃 PINK	予備線4 SPARE4

Output connector

2-1-7. Power switch

Push the upper part of power switch to turn on the power supply.

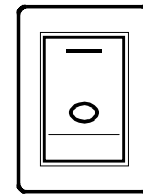

Power switch

2-2. Power cable

The power cable of 5m is attached by the standard. The power cable is a connector addition cable as connected with the output connector.

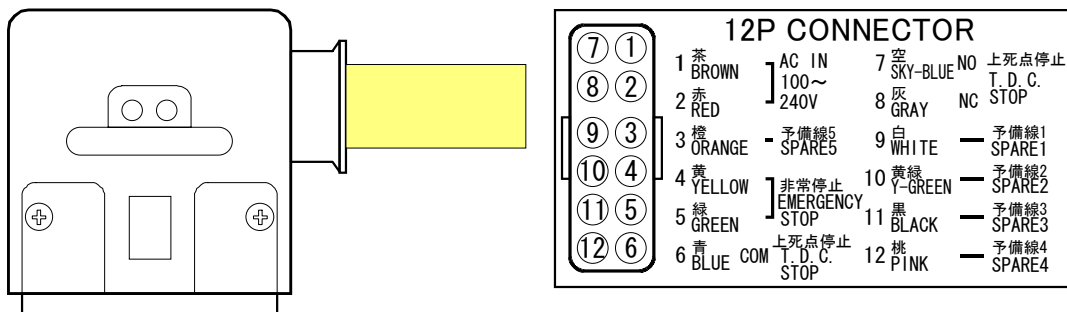

Power cable

2-3. SPRING sensor

PS-661 appends the six SPRING sensor. The spring sensor is a contact type sensor.

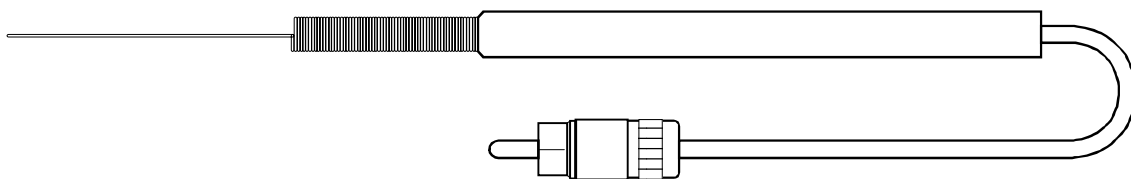

SPRING sensor

3. Functions

3-1. Malfunction detector

The malfunction detector consists of six detection channels. The detection channel observes the processing of the press device by the sensor input and detection-timing signal. When the malfunction is found, stop signal is output.

To do the detection operation, the detection channel is turned ON and the safety device is made monitor ON.

The continuous inhibition relay is turned off in monitor OFF. The change in monitor ON/OFF pushes the monitor button in the panel or turns the monitor input of the terminal block on and off.

If the detection timing of the predetermined number is input at monitor OFF, the safety device automatically becomes monitor ON. The number of timing input, which automatically becomes monitor ON is set in a device setting.

The detection channel outputs stop signal to the emergency or the T.D.C. stop relay. To which the detection channel outputs stop signal is decided by setting the detection mode. Moreover, the alarm output relay is turned on at the same time as outputting the stop, too.

Do the reset operation to release the stop output. Push the reset button of the panel or turn on the reset input of the terminal block about the reset operation.

The detection timing input has T1, T2, and TC. Which timing the detection channel uses is decided. Channel 1 and 2 and 3 use TC. Channel 4 uses T1. Channel 5 and 6 use T2.

The function setting can change a part of function of each detection mode of each channel. The content set by the function setting is stored in EEPROM. EEPROM can be memorized for a long time.

Input polarity, detection ON/OFF, and the detection mode of the detection channel are backed up with the battery. When the voltage of the battery decreases and the memory is lost, it is necessary to set the channel. The channel (panel) setting is replaced when the memory is lost by the content stored in EEPROM. Moreover, panel setting memory operation can change the content of EEPROM.

"E01" is displayed in the digital display at power on when the memory is lost.

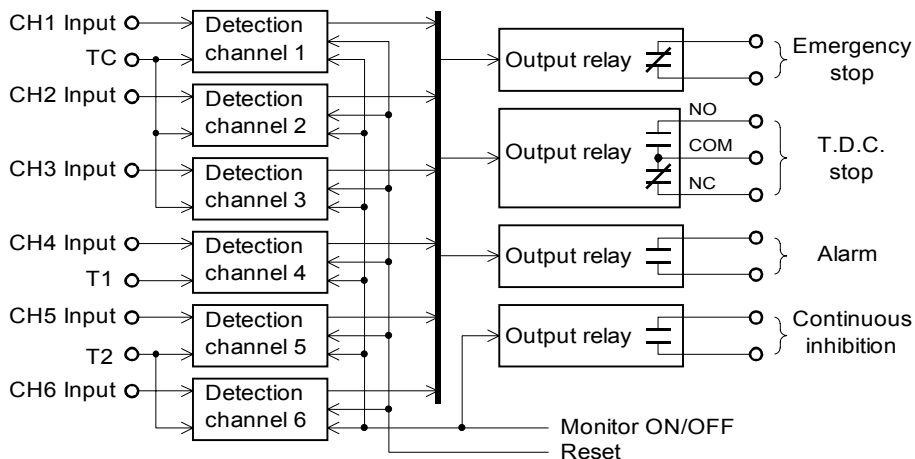

PS-661 block diagram

The contact close to the emergency stop output relay when the power of the safety device is turned off. The contact opens to alarm and the continuous inhibition output relay. Moreover, T.D.C. The output relay is close between COM-NC and opens between COM-NO.

This state is not influenced by the output polarity setting of the device setting.

3-2. Detection channel

The detection channel operation can change detection ON/OFF, the sensor input polarity, and the detection mode.

Pushing detection ON/OFF button of each channel can change ON/OFF of detection. If the safety device is monitor ON, detection ON/OFF can be confirmed with the operation/the detection lamp. When the lamp illuminates to green, it is detection ON. When the lamp is turned off, it is detection OFF.

The input polarity specifies an effective signal level of the sensor. Push detection ON/OFF button with A/B (reset) button pushed to change the input polarity. The input polarity is displayed by A or B.

When the input polarity is A, the signal becomes effective when the input is 0V(GND level). At B, the signal is effective when the input enters the state of opening.

The IN lamp illuminates when the input signal is effective. However, the IN lamp does not illuminate when detection OFF and the safety device is monitor OFF.

There are two detection modes in the detection channel. Push detection ON/OFF button with mode (monitor ON/OFF) button pushed to change the detection mode. The combination of two detection modes is different in each detection channel.

The stop signal output destination of the detection result is decided in the detection mode. As for the same detection channel, when the detection mode is changed, the output destination might be different.

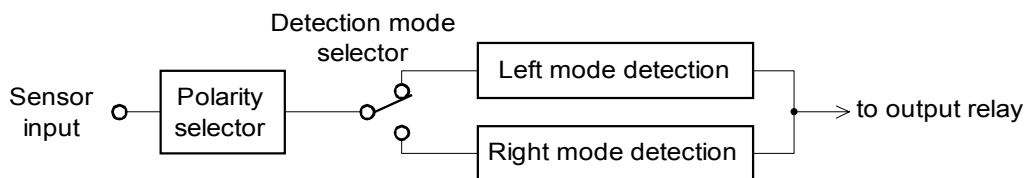

Detection channel

	Left detection mode (Output destination)	Right detection mode (Output destination)
Channel 1	XTRAC (T.D.C.)	TIMER (T.D.C.)
Channel 2	XTRAC (T.D.C.)	TOUCH (Emergency)
Channel 3	PASS (Emergency)	TOUCH (Emergency)
Channel 4	FEED (Emergency)	TOUCH (Emergency)
Channel 5	PASS (Emergency)	SYNC (Emergency)
Channel 6	PASS (Emergency)	TOUCH (Emergency)

(The function setting can change the destination of the output of the TOUCH detection.)

Allocation of detection mode

3-3. Sensor input

The sensor input can change the state of the input signal by setting the input polarity. When the input polarity is A, the signal becomes effective when the input is 0V(GND level). At B, the signal is effective when the input enters the state of opening.

The IN lamp illuminates when the input signal is effective.

The response to the signal of the sensor input is about 100 microseconds. The input circuit does not respond when the sensor signal is shorter than 100 microseconds occasionally. Be careful when the sensor, which generates a short signal, is used.

Connect the contact or the contact-less of the no-voltage with the sensor input. An internal circuit might break when the voltage is applied to the input.

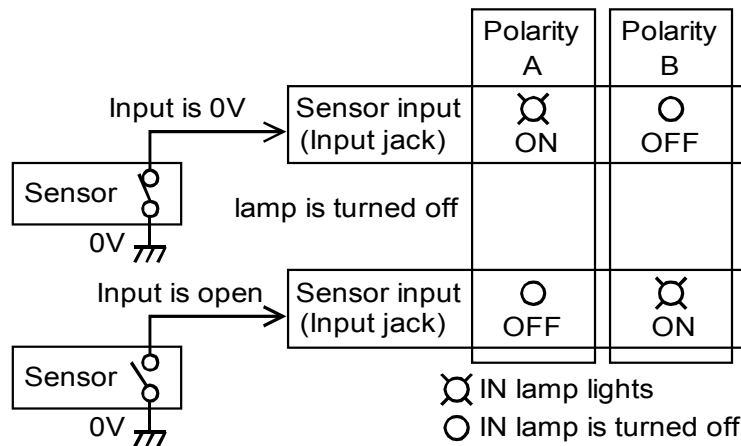

Input polarity and IN lamp

3-4. Detection timing input

As for the detection timing input, the input signal is turned on while opened.

Timing indicator lamp (T1, T2, and TC) illuminates to green when the detection timing is turned on.

The detection timing needs the width more than two milliseconds. Moreover, the device does not work normally when the signal with chattering is input.

Connect the contact or the contact-less of the no-voltage with the input. An internal circuit might break when the voltage is applied to the input.

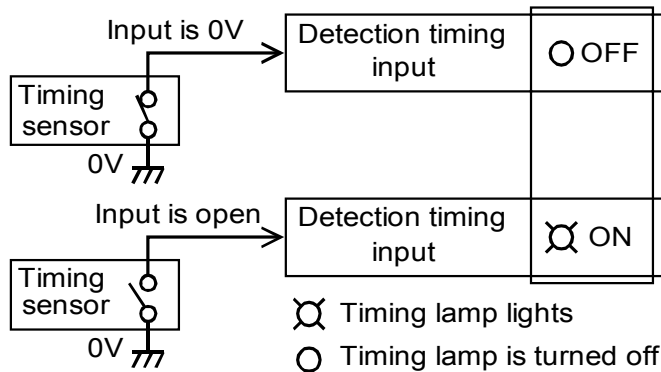

Detection timing input and timing lamp

3-5. Function setting

There is a function setting for assistance to the detection function. The content of each detection mode, which can be set, is different.

Detection mode (Mark)	Set content
Touch (TOUCH)	Output destination
Synchronization (SYNC)	Output destination
Passage (PASS)	Timing stretch time, input mask
Miss-feed (FEED)	Input delay time
Extraction (XTRAC)	Extraction number
Timer (TIMER)	Time of timer

Content of function setting

3-6. Detection mode

3-6-1.Touch detection

The touch detection always observes the sensor input. When the input signal becomes effective, stop signal is output.

The touch detection is used to detect the coil end or the bending when feeding of material.

The touch detection can change the stop output destination by the function setting.

The PS lamp and the Tx lamp do not shine, in the touch detection.

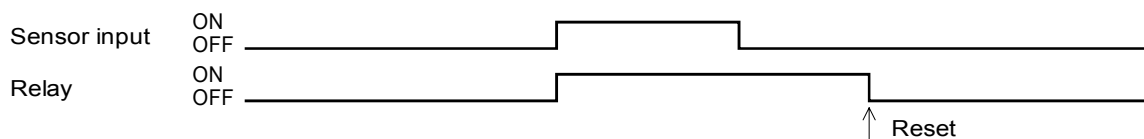

Touch detection

3-6-2.Synchronization detection

As for synchronization detection, when turning on the detection timing and the input signal are effective, stop signal is output.

The synchronization detection is used to detect the coil end or the bending when feeding of material. At detection timing ON, the synchronization detection is the same operation as the touch detection.

The synchronization detection can change the stop output destination by the function setting.

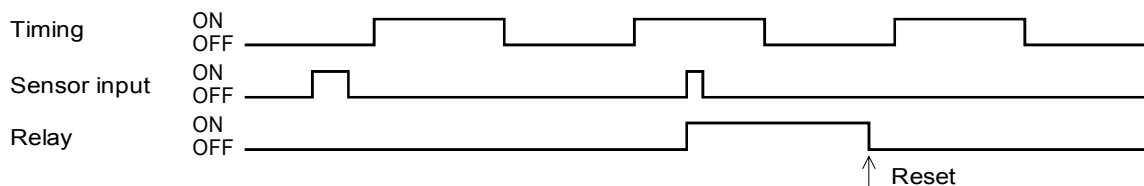

Synchronization detection

3-6-3. Passage detection

When the detection timing changes from turning on into turning off, the passage detection check the sensor input and the passage memory. After the check, the passage memory is reset.

The input signal is effective or the passage memory is not set when turning off the detection timing, stop signal is output.

The passage memory is set when the sensor input is effective. When the input mask is released by the function setting, the passage memory is set regardless of the detection timing.

If the input mask is set, the set of the passage memory is only a period of timing ON. The PS lamp illuminates when the passage memory is set.

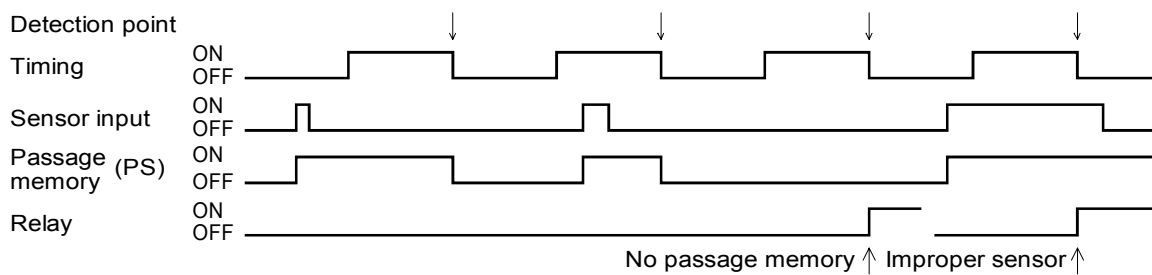

Passage detection to which input mask is released

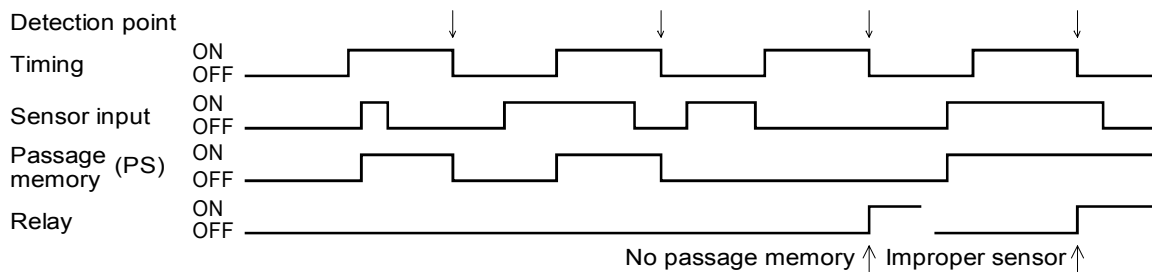

Passage detection where input mask is set

The function setting of the passage detection can set the timing stretch time. The timing stretch time can be set from 0 to 999 milliseconds. When the detection timing stretch time is set, the sensor input must be invalid by the time the stretch timing is turned off. The display of the Tx lamp and the confirmation and reset of the passage memory are done according to the source timing.

Large value setting at the timing stretch time causes the detection failure. Do not set a large value. Set the small value as much as possible at the timing stretch time.

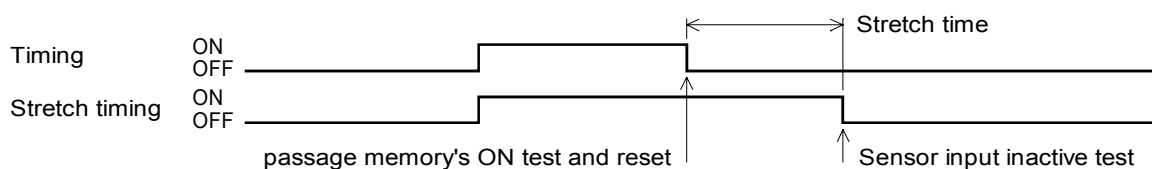

Stretch timing

3-6-4. Miss-feed detection

When the detection timing changes from turning on into turning off, the miss-feed detection check the sensor input and the passage memory. After the check, the passage memory is reset.

The input signal is effective or the passage memory is not set when turning off the detection timing, stop signal is output.

The passage memory is set when the sensor signal is effective.

In the miss-feed detection, the IN lamp illuminates when the sensor input becomes invalid. Note that the input display method is different from other detection modes.

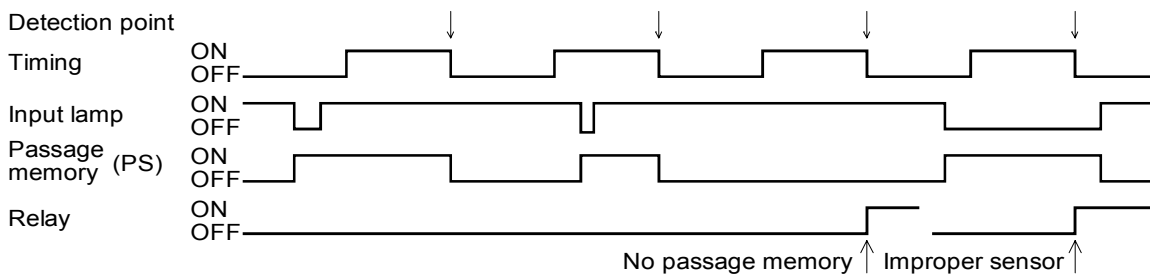

Miss-feed detection

In the miss-feed detection, the function setting can set the input delay time. The input delay time can be set from 0 to 255 milliseconds.

The input response time that sensor-input terminal is opened from GND level is set at the input delay time of the miss-feed detection. There is no delay when the sensor input becomes 0V from opening.

In the miss-feed detection by the method of the contact of the SPRING sensor to the material, it is likely to fail in detection from the uncertainty of the continuance contact. For this case, setting the input delay time can decrease the failure of detection.

When setting the input delay time is mistaken, normal detection cannot be done. Set the small value as much as possible at the input delay time.

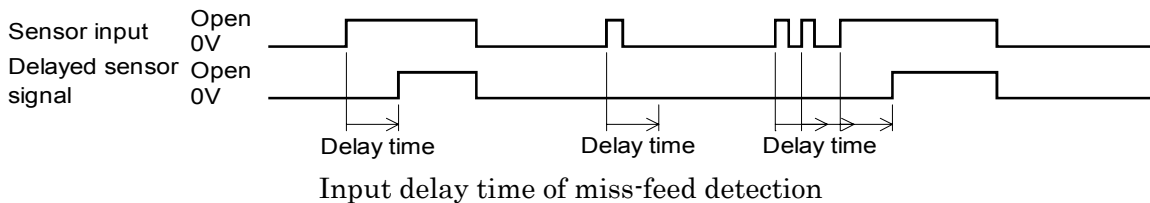

3-6-5.Extraction detection

The extraction detection is detection in which the counter is used. When the sensor-input changes effectively from invalidity, the number of extraction is loaded into the counter.

When the detection timing is turned on from turning off, one is decreased as for the value of the counter. When the count of the counter becomes 0, stop signal is output.

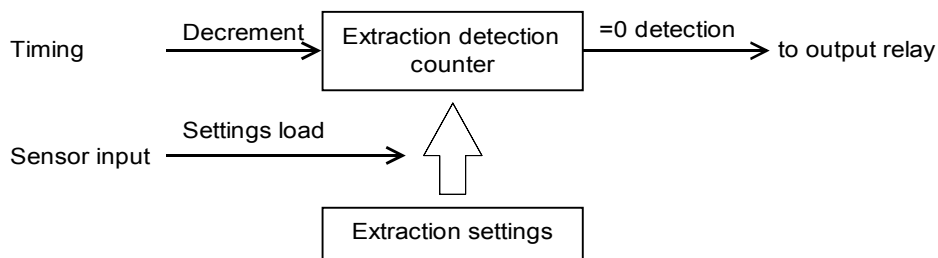

Extraction detection block diagram

The value of the extraction detection counter cannot be displayed.

The PS lamp illuminates at time when the count was decreased.

The function setting sets the number of extraction detection. The number of extraction detection can be set from 2 to 999.

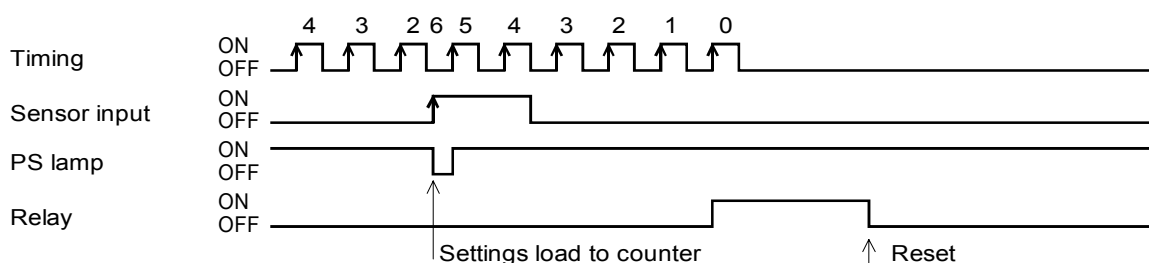

Extraction detection

3-6-6.Timer detection

When the sensor input is turned on continuously exceeding the timer set time, the timer detection outputs stop signal.

Detection is done while the timer is operating. When the detection timing is turned off from turning on, the timer begins operating. The timer stops operating for the reset operation.

The function setting sets the time of the timer. The time of the timer can be set from 0 to 9.99 seconds.

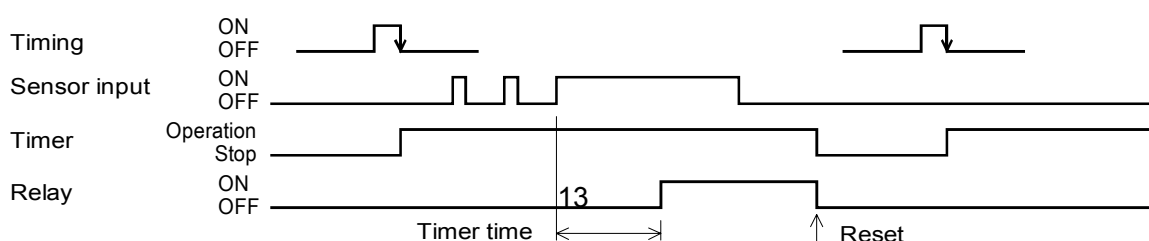

Timer detection

3-7. Automatic monitor ON

If the detection timing of the predetermined number is input while monitored OFF, the safety device automatically becomes monitor ON. Set the number of detection timing which becomes automatic monitor ON in the device setting. As for the number, 30 is set by standard value.

Stop signal is often output because input status is not steady immediately after automatic monitor ON.

3-8. Panel setting memory

Panel setting memory is to memorize setting operator control panel.

Sensor input polarity, detection channel ON/OFF, and the detection mode can be memorized in EEPROM by panel setting memory operation.

The panel setting is backup with the battery. The panel setting used by turning on the power before is reproduced.

The voltage of the battery decreases if the power supply is not turned on for two weeks or more and the memory is lost.

The content, which EEPROM memorizes to turn on the power with the memory lost, becomes panel setting.

The memory of EEPROM can be panel setting in the device setting at the time of each power turning on.

3-9. Device setting

The function setting of the device can be changed in the device setting. Refer to the device setting for details.

4. Operation

4-1. Monitor ON/OFF

Monitor ON/OFF changes the state of the safety device. When monitor ON/OFF button is pushed, monitor ON and monitor OFF are changed. Moreover, even if the monitor input in the terminal block is turned on and off, it is possible to change.

It is not possible to do in monitor OFF when there is a channel by which the operation/the detection lamp blinks red.

Do monitor ON/OFF operation after the operation of reset when the operation/the detection lamp blinks red.

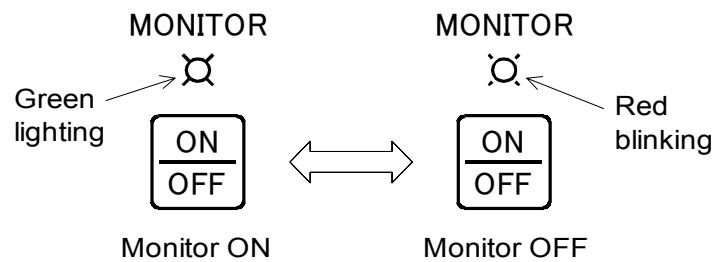

Monitor ON/OFF operation

4-2. Release of stop output

The operation/the detection lamp of the channel, which detects the malfunction, blinks red. Stop signal is output at this time.

Push the reset button to release the stop output. Moreover, the reset input in the terminal block can be released about turning on.

However, the detection channel used by touch detection or synchronization detection might not be able to release the stop output. Push the reset button after invalidating the sensor input at this.

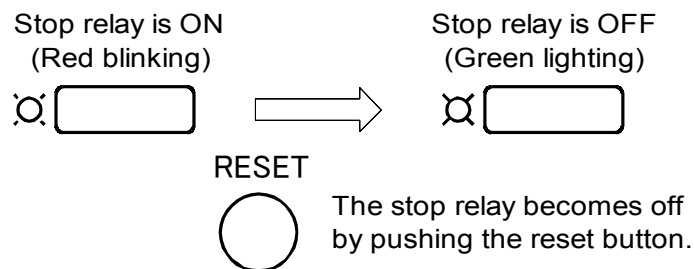

Release of stop output

4-3. Detection ON/OFF of channel

Push the detection ON/OFF button to change ON/OFF of the detection channel.

The operation/the detection lamp illuminates to green when becoming detection ON. However, the lamp does not illuminate at monitor OFF.

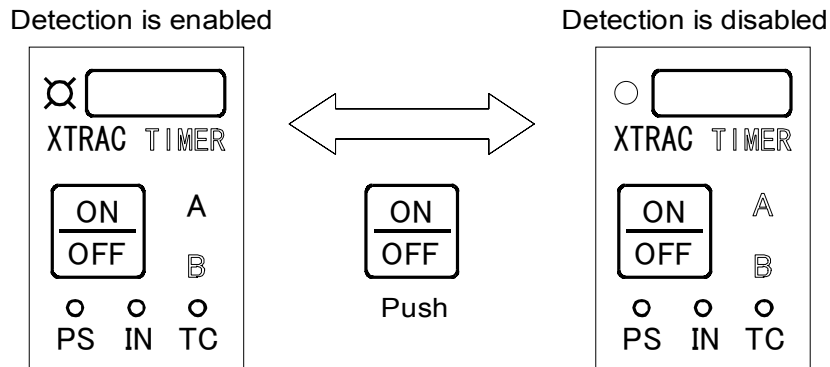

Detection ON/OFF of channel

4-4. Change of input polarity

Push detection ON/OFF button with A/B (reset) button pushed to change the sensor input polarity.

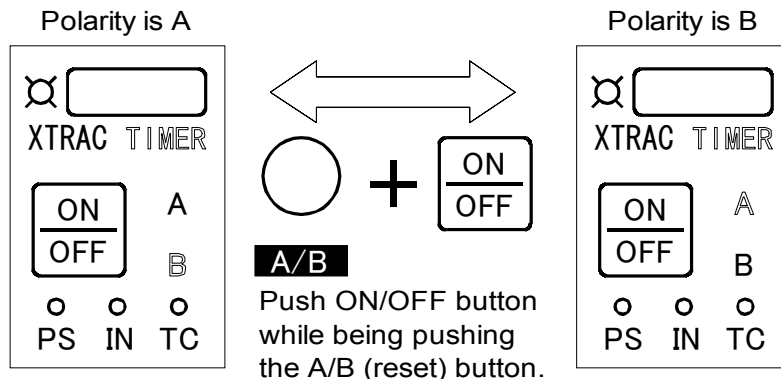

Change of input polarity

4-5. Change of detection mode

Push detection ON/OFF button with mode (monitor ON/OFF) button pushed to change the detection mode.

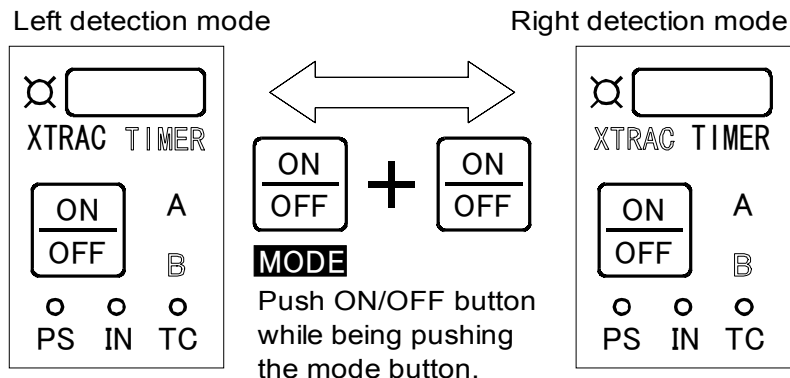

Change of detection mode

4-6. Function setting

Select the detection mode of the detection channel, which tries to set the function. Make to monitor OFF and keep pushing detection ON/OFF button of the set channel for two seconds. The figure, which blinks to the digital display, is displayed when becoming the function set.

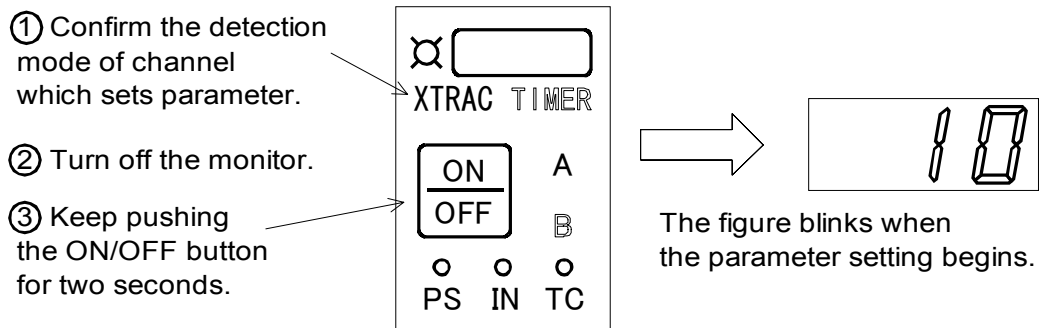

Start of function setting

The function of the button in the panel is changed in the function setting.

The ON/OFF button of channel 5 and 6 is used for a numeric change.

The ON/OFF button of channel 3 and 4 is used to move the blinking position.

The ON/OFF button of channel 2 is used to change in the decimal point.

The ON/OFF button of channel 1 is not used.

To end setting, the monitor button is pushed. When setting is ended, the detection operation is restarted.

To interrupt setting, the reset button is pushed. The detection operation is restarted without changing the set point when setting is interrupted.

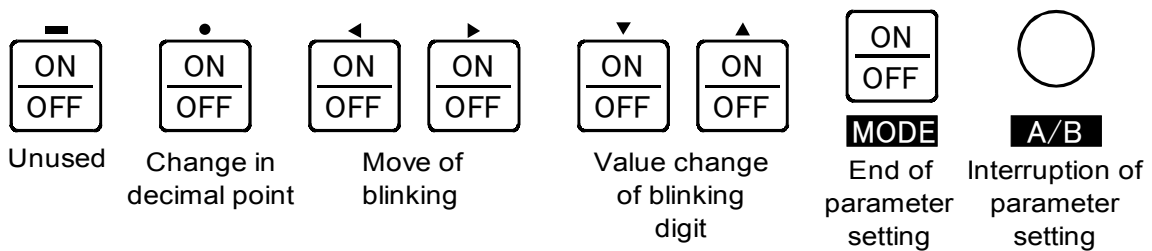

The function of the button in the function setting

4-6-1.Touch and synchronization detection

The function setting of touch and synchronization detection is change of stop output destination.

0 or 1 is displayed in the digital display. Setting 0 makes the emergency stop an output destination. Setting 1 makes the T.D.C. stop an output destination.

4-6-2.Extraction detection

The function setting of the extraction detection sets the extraction number.

Set the extraction number from 2 to 999. The safety device does not work normally when 0 or 1 is set to the extraction number.

4-6-3.Timer detection

The time of the timer is set in the function setting of the timer detection.

The time of the timer can be set from 0.00 to 9.99. The unit is a second.

4-6-4.Miss-feed detection

Set the input delay time in the function setting of the miss-feed detection.

The input delay time can be set from 0 to 255. When the value, which exceeds 255 at the input delay time, is set, 255 is set. The unit is a millisecond.

4-6-5.Passage detection

Set the timing stretch time and input mask in the function setting of the passage detection.

Set the small value as much as possible at timing stretch time.

The timing stretch time can be set from 0 to 999. The unit is millisecond.

The decimal point displays setting the input mask. The input mask is effective when there is a decimal point. When the decimal point goes out, the input mask is invalid.

4-7. Panel setting memory

Push at the same time for two seconds in order of reset, monitor ON/OFF, and channel 2 ON/OFF button, after making the safety device monitor OFF.

When the processing of the panel setting memory is completed, "End" is displayed in the digital display. When the reset button is pushed after this, the operation is completed.

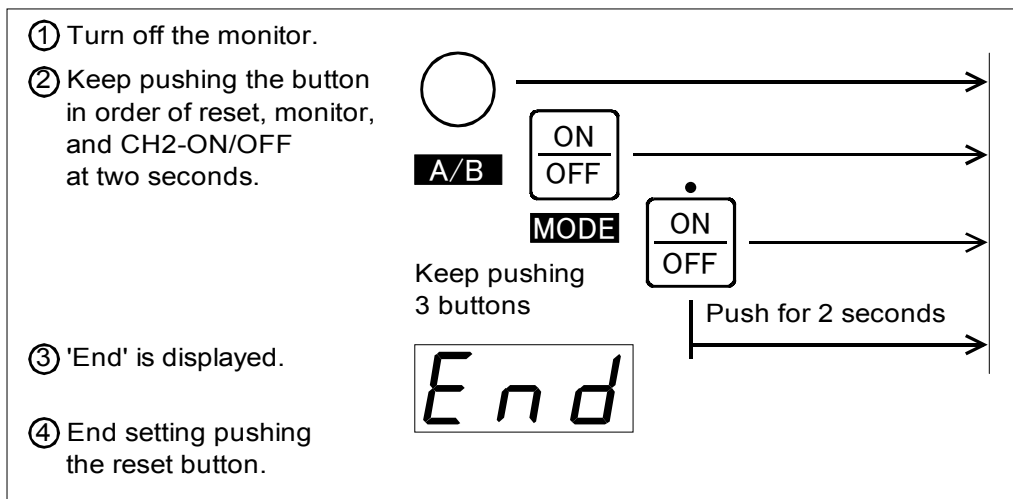

Panel setting memory

5. Installation

5-1. Installation of safety device

Install the used with the safety device as for a special bracket. Moreover, using the stacking bracket can pile safety device and other products of our company. Select an installation place with less vibration and dust. Avoid a place exposed to oil and metal powder.

Be sure to ground the safety device chassis. If grounding is incomplete, the contact type sensor dose not works.

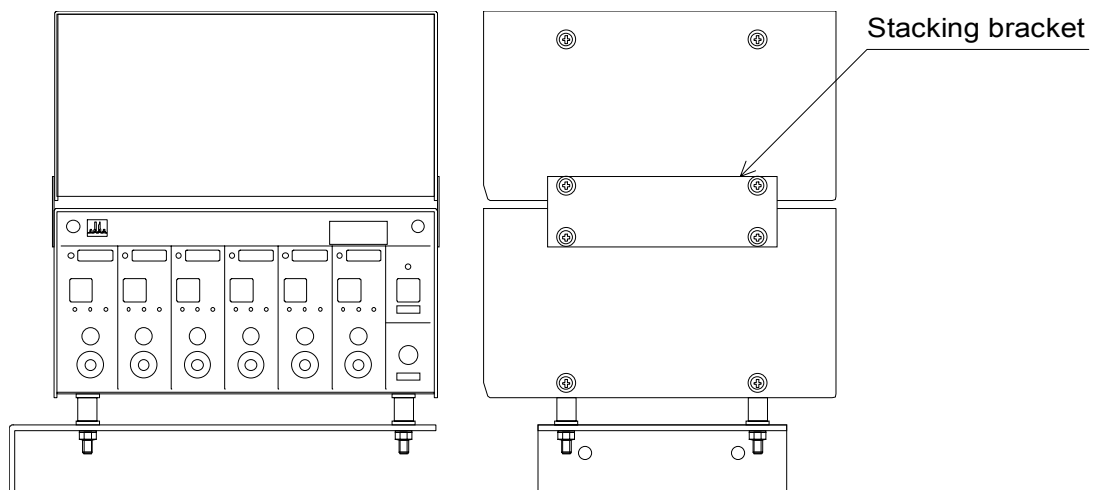
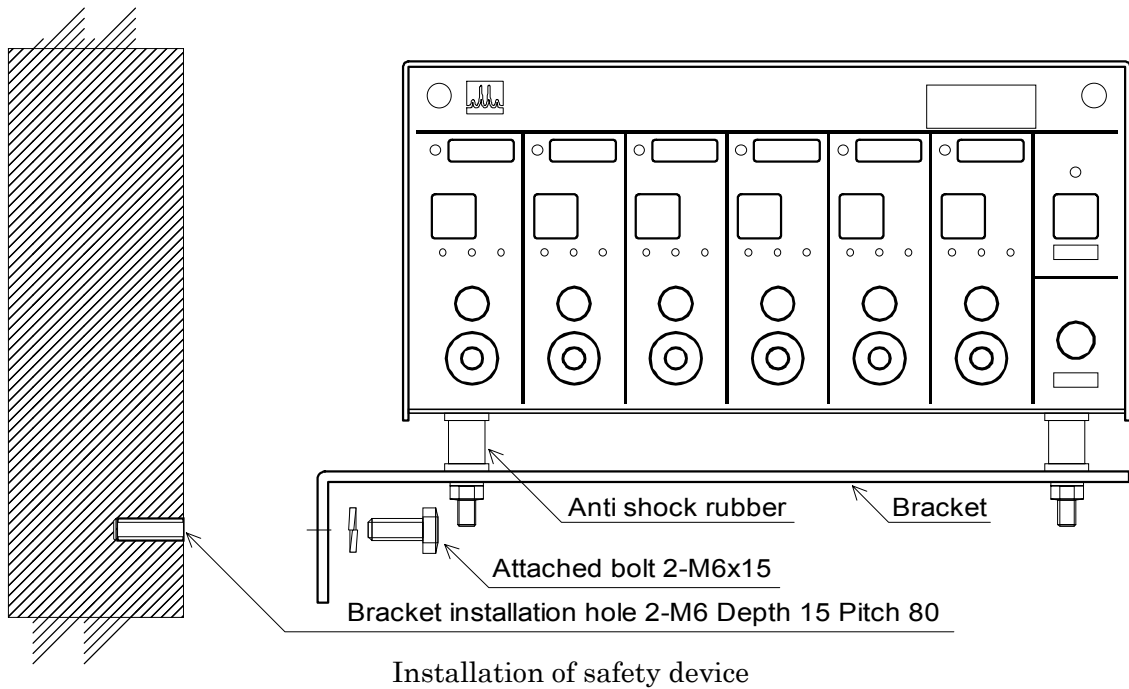

Installation with stacking bracket

5-2. Connection of power supply

Connect the operation power of the press machine to power cable 1 (Brown) and 2 (Red).

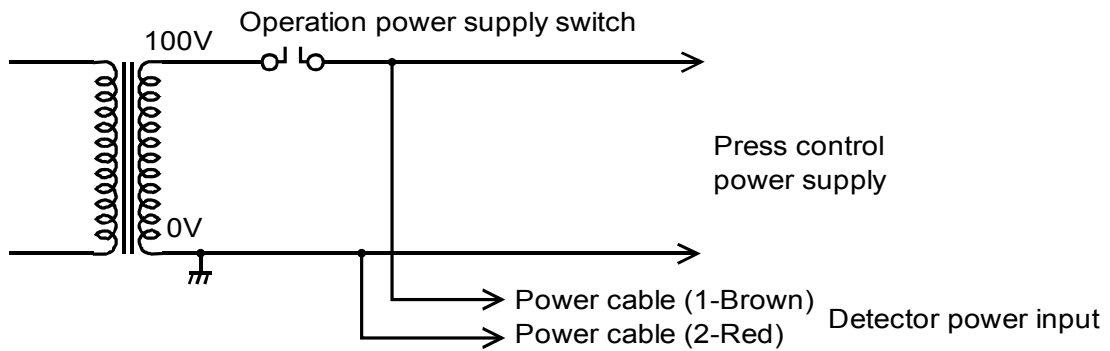

Connection of power supply

5-3. Connection of stop output

Connect 4 (Yellow) and 5 (Green) of power cable to emergency stop circuit of press machine.

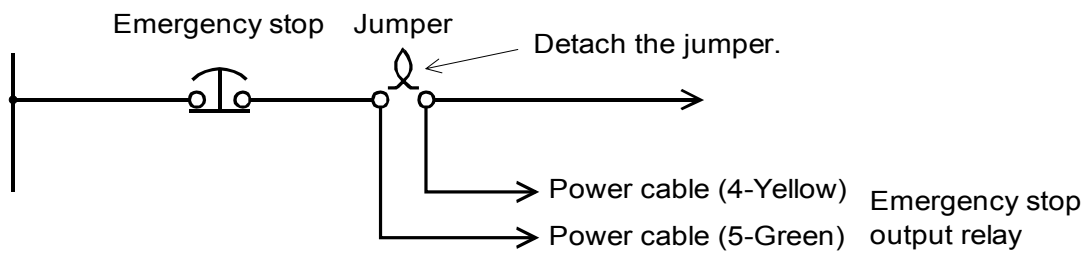

Connection of emergency stop output

Connect 6 (Blue) and 8 (Gray) of power cable to T.D.C. stop circuit of press machine.

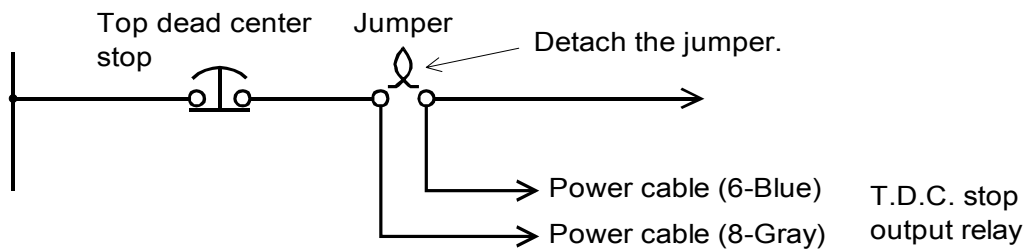

Connection of T.D.C. stop output

5-4. Connection of continuous inhibition output

The continuous inhibition output is turned on when the safety device is monitor ON.

Only when the safety device is monitored ON, continuous running of the press machine can be limited by connecting the continuous inhibition output with the circuit of the operation selector.

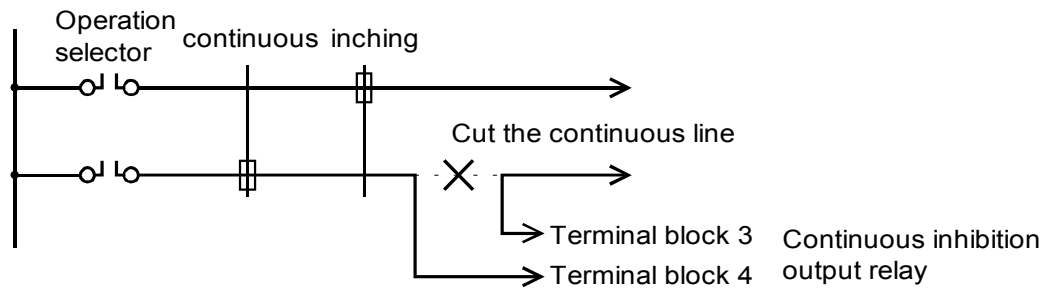

Connection of continuous inhibition output

5-5. Connection of alarm output

Alarm output can operate the alarm device such as buzzer and the warning light, etc.

The alarm output is turned on while the stop output is being output.

Prepare the power supply for the alarm device when you use the alarm output.

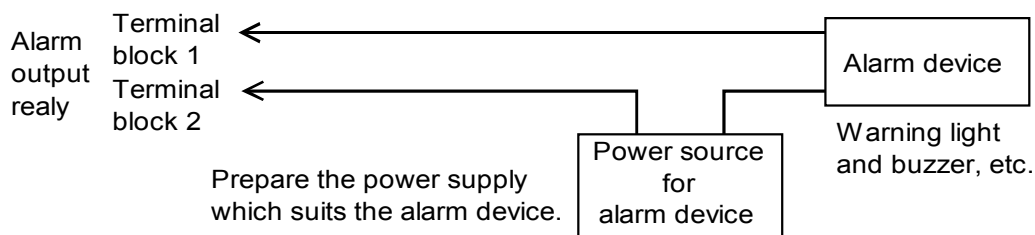

Connection of alarm output

5-6. Connection of external reset and monitor ON/OFF switches.

They can operate from the remote place by connecting the switch for reset and monitor ON/OFF with the terminal block input and will be convenient.

Especially, it is not necessary to connect the switches.

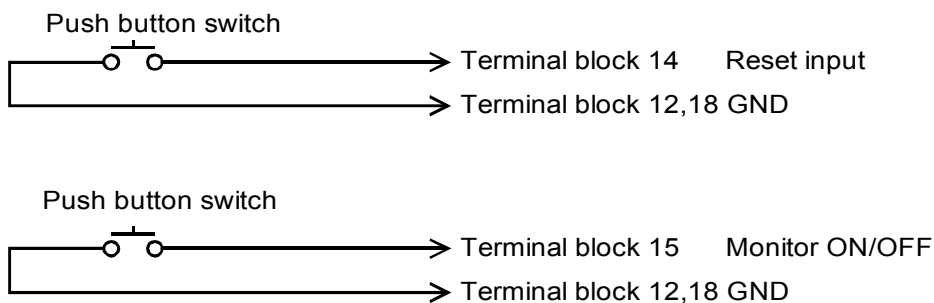

Connection of external switches

5-7. Connection of operation inhibition switch

The switch, which turns the operation inhibition function on and off can be connected. Especially, the switch need not be connected.

When the switch is turned on, the button of safety device cannot be operated.

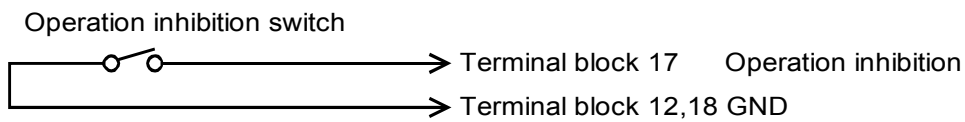

Connection of operation inhibition switch

5-8. Connection of detection timing inputs

Connect the contact or the contact-less of the no-voltage signal with detection timing input (T1, T2, and TC) in the terminal block.

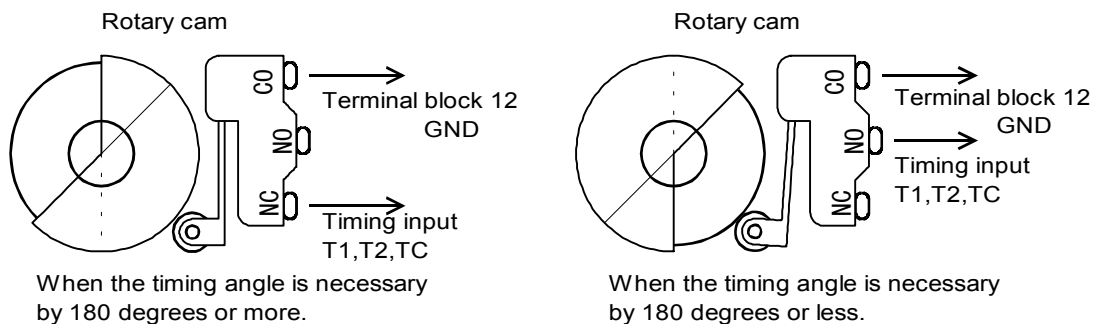

Example of detection timing connection

5-9. Connection of sensors

Install the pin plug or three pole plug in a sensor on the market.

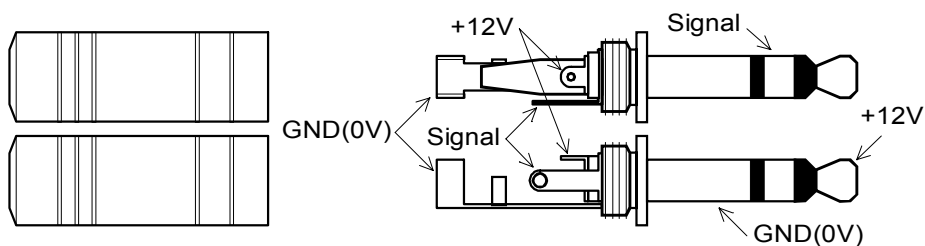

Three pole plug

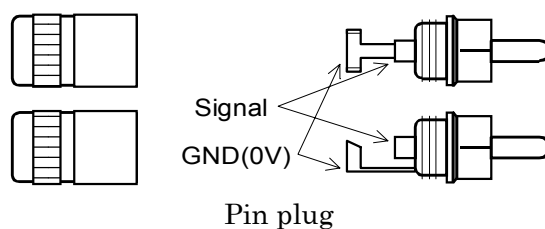

Pin plug

6. Device setting

The device setting can change a part of the operation of the safety device.

Do the device setting after switching from the normal operation to the device set mode.

Attention: Do the device set operation after confirming the program version displayed in the digital display at power on is the same as the version of the cover of this manual. When the version is different, a set content is also different. The safety device does not work normally when setting is changed without confirming the version.

6-1. Switch to device set mode

Turn the safety device to monitor OFF by the normal operation. Leave three buttons pushed in order of reset, monitor ON/OFF and channel 1 ON/OFF at two seconds.

The figure ('01', item number) is displayed to higher two digits of the digital display when changing into the device set mode.

6-2. Item number setting, display and change in set content

Set the item number by operating the arrow button. The blinking numerical value can be changed with the upper and lower arrow button. The blinking position can be changed with the right and left arrow button.

Push monitor ON/OFF button after setting the item number. The digital display changes into the display of the content of the item number if monitor ON/OFF button is pushed.

A set content can be changed with the arrow button as well as setting the item number.

Setting is value of three digits or 1/0 of three items. Confirm a set content of each item number.

When monitor ON/OFF button is pushed with a set content displayed, setting is stored. When the reset button is pushed instead of the monitor ON/OFF button, setting is not stored. The digital display returns to the item number.

6-3. End of device set mode

Push the channel 1 ON/OFF (-) button with the item number displayed to the end of the device set mode. The safety device returns to the normal operation.

6-4. Initialization of setting

Set the item number in 00, 99 or 98 and keep pushing the CH2 detection ON/OFF button at two second.

In item number 00, the device setting and the panel setting return to the state of the shipment.

In item number 99, the function setting returns to the state of the shipment.

In item number 98, the backup with the battery is released.

6-5. Details of setting

6-5-1. Automatic returns count (item number 1)

Set the detection timing input count, which becomes monitor ON from monitor OFF in the automatic return count.

Setting can be set from 0 to 255. If 256 or more is set, setting becomes 255.

It is not possible to return automatically when setting is adjusted to 0.

Initial value 30

6-5-2. Reset output time (item number 2)

Set the time output from the reset input terminal of the terminal block at the reset output time. If the reset button in the panel is pushed, the reset input of the terminal block is temporarily output.

Setting can be set from 0 to 999. A set unit is a millisecond. When setting is adjusted to 0, the input terminal is not output.

The reset output can notify other devices for the reset button of the panel to have been pushed.

Initial value 200

6-5-3. Monitor ON/OFF output time (item number 3)

Set the time output from the monitor input terminal of the terminal block at the monitor ON/OFF output time. If the monitor ON/OFF button in the panel is pushed, the monitor input of the terminal block is temporarily output.

Setting can be set from 0 to 999. A set unit is a millisecond. When setting is adjusted to 0, the input terminal is not output.

The monitor output can notify other devices for the monitor ON/OFF button of the panel to have been pushed.

Initial value 0

6-5-4. Output polarity 1 (item number 4)

Set the polarity of the relay output in output polarity 1. It is setting of 0/1 of each digit.

A set content is displayed from a right digit in order of the emergency stop, the T.D.C. stop, and alarm.

The relay contact opens because of output ON when setting is adjusted to 0. And, close when settings adjusted to one.

Initial value 011

6-5-5. Output polarity 2 (item number 5)

Set the polarity of the continuous inhibition output relay in output polarity 2. It is setting of 0/1 of each digit.

Set only the least significant digit in the display though it is treble. Two digits of the remainder are the reserves.

Initial value 000

6-5-6.Input polarity 1 (item number 6)

Set the detection timing input polarity in input polarity 1. It is setting of 0/1 of each digit.

A set content is displayed from a right digit in order of T1, T2, and TC.

If one is set, the detection timing is turned on because of the input terminal opening.

Initial value 111

6-5-7.Input polarity 2 (item number 7)

Set the operation inhibition input polarity in input polarity 2. It is setting of 0/1 of each digit.

Set only the most significant digit in the display though it is treble. Tow digits of the remainder are the reserve.

Initial value 000

6-5-8.System setting (item number 8)

A set content is displayed from a right digit in order of the monitor ON/OFF at power on, the all PS reset, and the panel setting at system setting. They are 0/1 setting of each content.

The monitor ON/OFF at power on specifies whether to make the safety device monitor ON or monitor OFF by turning on the power supply. When 0 is set, monitor OFF is selected. When 1 is set, monitor ON is selected.

The all PS reset specifies 'do reset' or 'do not reset' the passage memory by the reset operation. When one is set, 'do reset' is selected.

The panel setting specifies 'from back up memory' or 'form EEPROM' to panel setting at power on. When 0 is set, 'from back up memory' is selected. When one is set, 'from EEPROM' is selected.

Initial value 001

6-5-9.Reservation item (item number 9)

Do not change this reservation item. Initial value 000

6-5-10.Option output (item number 10)

Set the option output when you increase the parallel output unit.

6-5-11.Operation inhibition setting 1 (item number 11)

Set the operation inhibited by the operation inhibition function to setting operation inhibition setting 1. They are 0/1 setting of each content. When 1 is set, the operation is inhibited.

A set content is displayed from a right digit in order of the detection ON/OFF, the input polarity change, and the detection mode selection.

Initial value 111

6-5-12.Operation inhibition setting 2 (item number 12)

Set the operation inhibited by the operation inhibition function to setting operation inhibition setting 1. They are 0/1 setting of each content. When 1 is set, the operation is inhibited.

A set content is displayed from a right digit in order of the monitor ON/OFF, the reset, and the reserve. Do not change the reserve.

Initial value 000

6-5-13.Input signal processing time (item number from 13 to 18)

Set time of the processing of the signal of the terminal block input to the input signal processing time. Setting the each item is from 0 to 255. A set unit is a millisecond.

Item number 13	T1	initial value 20
Item number 14	T2	initial value 20
Item number 15	TC	initial value 20
Item number 16	reset	initial value 20
Item number 17	monitor ON/OFF	initial value 20
Item number 18	operation inhibition	initial value 20

6-6. Set item list (V1.0x)

Item No.	Function	setting	Initial value	
01	Automatic returns count	0-255	30	
02	Reset output time	0-999	200mS	
03	Monitor ON/OFF output time	0-999	0mS	
04	Output polarity 1	0/1	011	alarm, T.D.C., emergency
05	Output polarity 2	0/1	000	reserve, reserve, cont. inhibit
06	Input polarity 1	0/1	111	TC, T2, T1
07	Input polarity 2	0/1	000	OPIH, reserve, reserve
08	System setting	0/1	001	panel, PS reset, monitor on/off
09	Reservation item	0/1	000	
10	Option output		0	
11	Operation inhibition setting 1	0/1	111	mode, A/B, ON/OFF
12	Operation inhibition setting 2	0/1	000	reserve, reset, monitor
13	processing time T1	0-255	20mS	
14	processing time T2	0-255	20mS	
15	processing time TC	0-255	20mS	
16	processing time Reset	0-255	20mS	
17	processing time Monitor	0-255	20mS	
18	processing time Inhibition	0-255	20mS	
00	Device item initialize			
99	Panel setting initialize			
98	Back up release			

7. Specification and performance

7-1. Detection

Detection channels	6
Detection timings	3
Power source for sensor	DC12V 600mA max.
Detection style	
Channel 1	extraction (XTRAC), timer (TIMER)
Channel 2	extraction (XTRAC), touch (TOUCH)
Channel 3	passage (PASS), touch (TOUCH)
Channel 4	miss-feed (FEED), touch (TOUCH)
Channel 5	passage (PASS), synchronization (SYNC)
Channel 6	passage (PASS), touch (TOUCH)

7-2. Input circuit

Input specification	internal volt system (12VDC)
H level	Over 9.0V / Under 1mA
L level	Under 3.0V / Over 8mA (Max 12mA)
Input circuit	

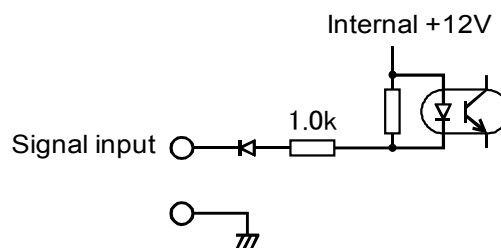

7-3. Output circuit

Output	Emergency, T.D.C., Alarm, Continuous inhibition
Output device	Relay contact (no voltage)
Voltage (Max)	250VAC, 30VDC
Current (Max)	2.0A (inductive load)

7-4. Power supply

Power voltage	AC100 to 240V +/-10% 50/60Hz
Power consumption	20VA (Max)

7-5. Other specifications

Memory backup	2 weeks (Min) 5 hours after the continuous duty
Weight	2.4kgW
Dimensions (W/H/D)	200 x 98.5 x 184 mm Projection parts are not insulated.
Environmental temperature	0 to 55 degree C
Environmental humidity	35 to 85%
Environmental atmosphere	Corrosive gas and dust should not exist.

8. Dimensions

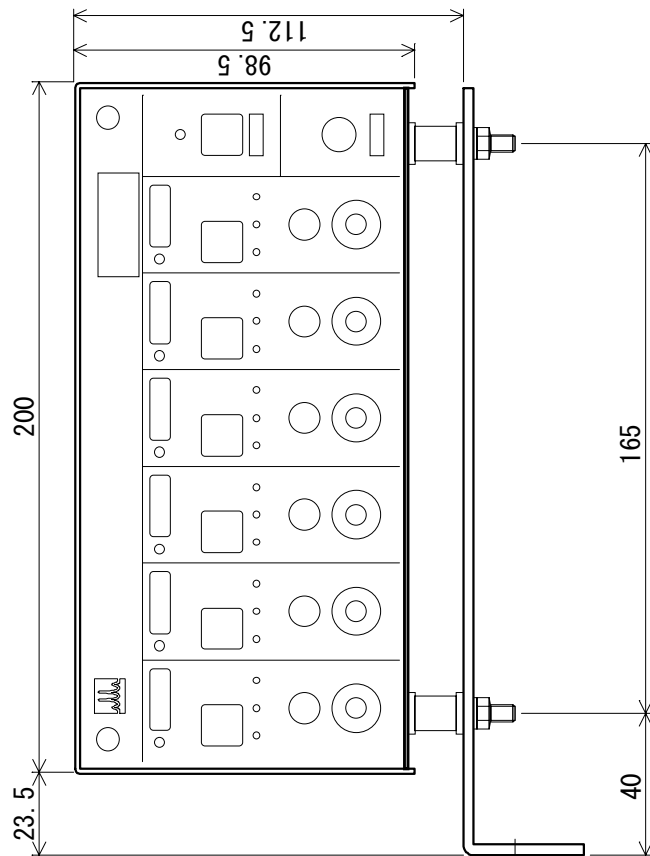
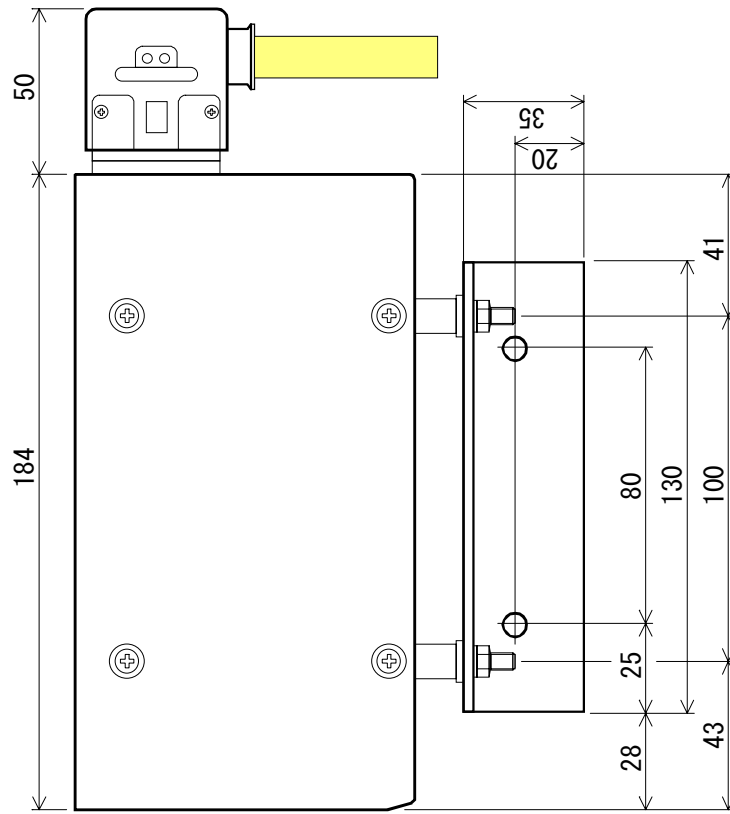

WARRANTY

All Sugiyama Electric System products are warranted against defective materials and workmanship for one year from the date of delivery. Any questions with respect to the warranty should be taken up with your Sugiyama Electric System Field Engineer or agents.

All requests for repairs and replacement parts should be directed to the Sugiyama Electric System Office or agents in your area. This will assure you the fastest possible service. Please include the instrument Type Number or Part Number and Serial Number with all requests for parts or service.

Specifications and price change privileges reserved.

SUGIYAMA ELECTRIC SYSTEM INC.

1-30, KAMITAKABATA, NAKAGAWA-KU, NAGOYA 454-0873 JAPAN

TEL 81-52-363-0501 FAX 81-52-351-7585